

Pressure relief valve, pilot operated

RE 25802/10.05
Replaces: 03.03

1/20

Types DB and DBW

Sizes 10 to 32
 Component series 5X
 Maximum operating pressure 350 bar
 Maximum flow 650 L/min

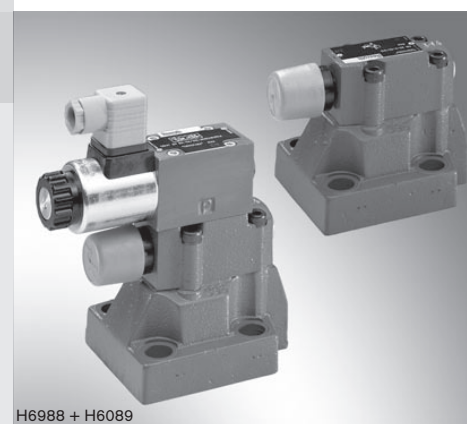

Table of contents

Contents	Page
Features	1
Ordering code	2
Cable sockets	3
Symbols	4
Standard types	4
General notes	5
Function, section	5, 6
Technical data	7
Characteristic curves	8, 9
Unit dimensions	10 to 14
Type-tested safety valves of type DB(W)...E, component series 5X, to Pressure Equipment Directive 97/23/EC (in the following "PE " in short)	
Ordering code	15
Deviating technical data	16
Safety notes	16 to 18

Information on available spare parts:
www.boschrexroth.com/spc

Features

- For subplate mounting:
 - Porting pattern to ISO 6264-AR-06-2-A (size 10),
 - ISO 6264-AS-08-2-A (size 25),
 - ISO 6264-AT-10-2-A (size 32)
- For threaded connection
- For installation into manifolds
- 4 adjustment elements for pressure setting, optional:
 - Rotary knob
 - Sleeve with hexagon and protective cap
 - Lockable rotary knob with scale
 - Rotary knob with scale
- 5 pressure stages
- Solenoid operated unloading via built-on directional spool valve or directional poppet valve
- Heavy duty solenoid
- Explosion-protected solenoid (on enquiry)
- Switching shock damping, optional (only type DBW)
- Further information:
 - High-performance directional valves RE 23178 and RE 22058
 - Subplates RE 45064

Symbols

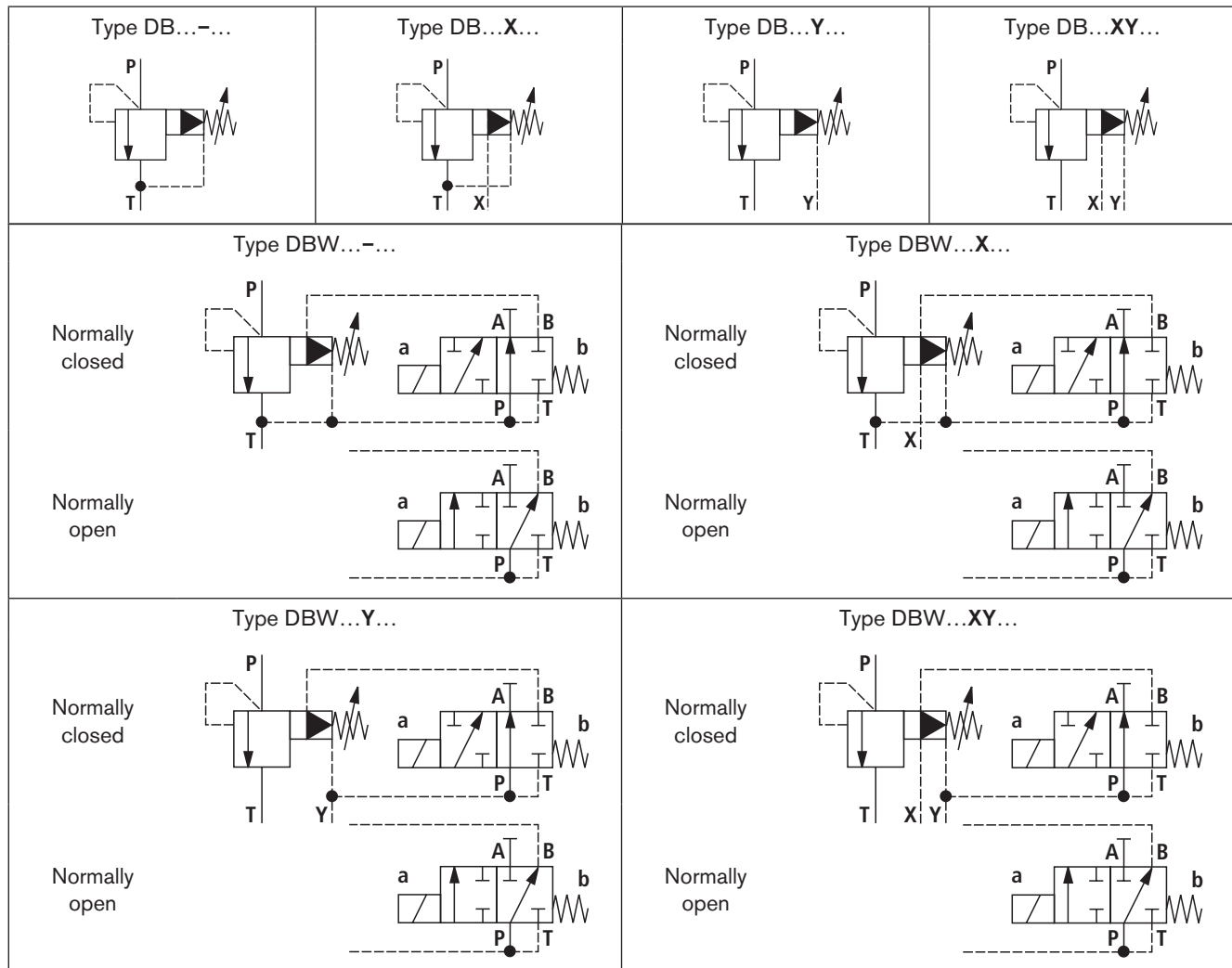

Standard types

Type	Material number
DB 10-2-5X/50	R900590645
DB 10-2-5X/100	R900590646
DB 10-2-5X/200	R900587772
DB 10-2-5X/315	R900590334
DB 10-2-5X/350	R900597992
DB 20 -2-5X/50	R900597212
DB 20 -2-5X/100	R900589433
DB 20 -2-5X/200	R900590768
DB 20 -2-5X/315	R900593530
DB 20 -2-5X/350	R900590618
DB 20 G2-5X/50	R900590328
DB 20 G2-5X/200	R900597307
DB 20 G2-5X/315	R900597747
DB 20 G2-5X/350	R900599232

Type	Material number
DB 30-2-5X/50	R900593564
DB 30-2-5X/100	R900594677
DB 30-2-5X/200	R900588131
DB 30-2-5X/315	R900591128
DB 30-2-5X/350	R900504902
DB 30 G2-5X/50	R900598338
DB 30 G2-5X/100	R900502598
DB 30 G2-5X/200	R900500719
DB 30 G2-5X/315	R900594426
DB 30 G2-5X/350	R900535222

Further standard types and components can be found in the EPS (standard price list).

General notes

- The unloading function (directional valve function on DBW) must not be used for safety-related functions!
- Type DBW..B..5X/... changes to the lowest settable pressure (circulation pressure) in the event of a power failure or cable break.
Type DBW..A..5X/... changes over to the pressure limitation function in the event of a power failure or cable break.
- In the case of internal pilot oil drain, hydraulic backpressures in port T, or, in the case of external pilot oil drain, hydraulic backpressures in port Y, fully add to the response pressure of the valve set on the pilot control.

Example:

Pressure setting of the valve by spring-pretensioning (item 12 on page 5) in the pilot valve/adjustment unit
 $p_{\text{spring}} = 200 \text{ bar}$

Hydraulic backpressure in port T with internal pilot oil drain $p_{\text{hydraulic}} = 50 \text{ bar}$

\Rightarrow Response pressure = $p_{\text{spring}} + p_{\text{hydraulic}} = 250 \text{ bar}$

Function, section: Type DB...

General

Pressure control valves of types DB and DBW are pilot operated pressure relief valves. They are used for the limitation (DB) or limitation and solenoid operated unloading (DBW) of the operating pressure.

Pressure relief valves (DB) basically consist of main valve (1) with main spool insert (3) and pilot valve (2) with pressure adjustment element.

Pressure relief valve type DB

The pressure present in channel P acts on main spool (3). At the same time, the pressure is applied via pilot lines (6) and (7) that are provided with orifices (4) and (5) to the spring-loaded side of main spool (3) and to ball (8) in pilot valve (2). When the pressure in channel P rises to a value above that set on spring (9), ball (8) opens against spring (9). The signal for

this process is provided internally via pilot lines (10) and (6) from channel P. The hydraulic fluid on the spring-loaded side of main spool (3) can now flow via pilot line (7), orifice bore (11) and ball (8) into spring chamber (12). From here, it is fed internally via pilot line (13) in the case of type DB...-, or externally via pilot line (14) in the case of type DB...Y, back to the tank. Orifices (4) and (5) generate a pressure differential across main spool (3), and the connection from channel P to channel T opens. The hydraulic fluid now flows from channel P to channel T while the set operating pressure is maintained.

The pressure relief valve can be unloaded or changed over to another pressure (second pressure stage) via port "X" (15).

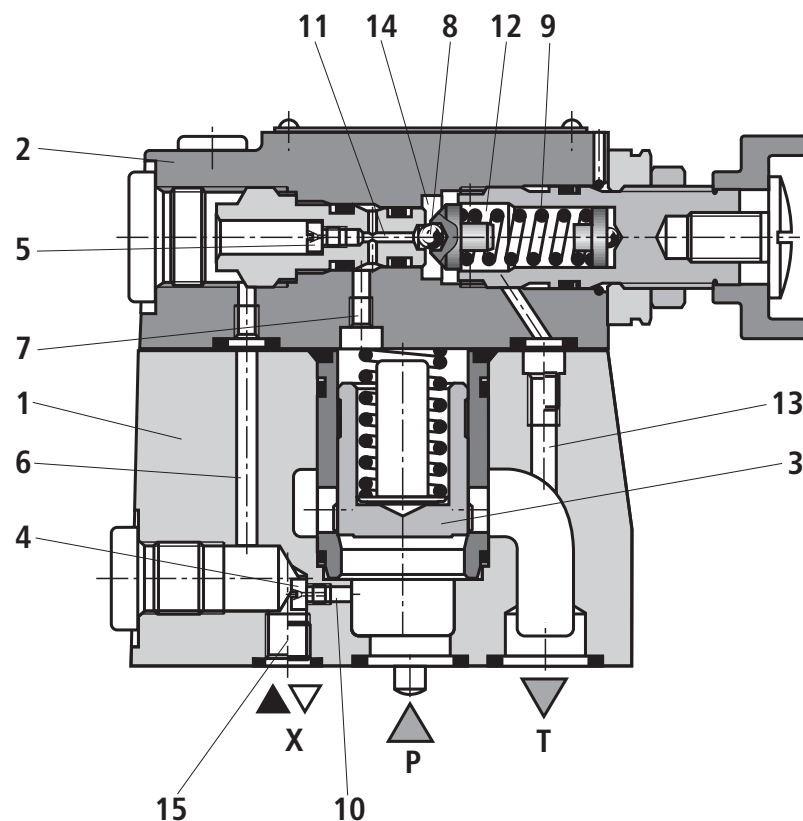

Function, section: Type DBW...

Pressure relief valve type DBW

In principle, the function of this valve corresponds to that of type DB. However, unloading through main spool (3) is achieved by operating the built-on directional spool valve (16).

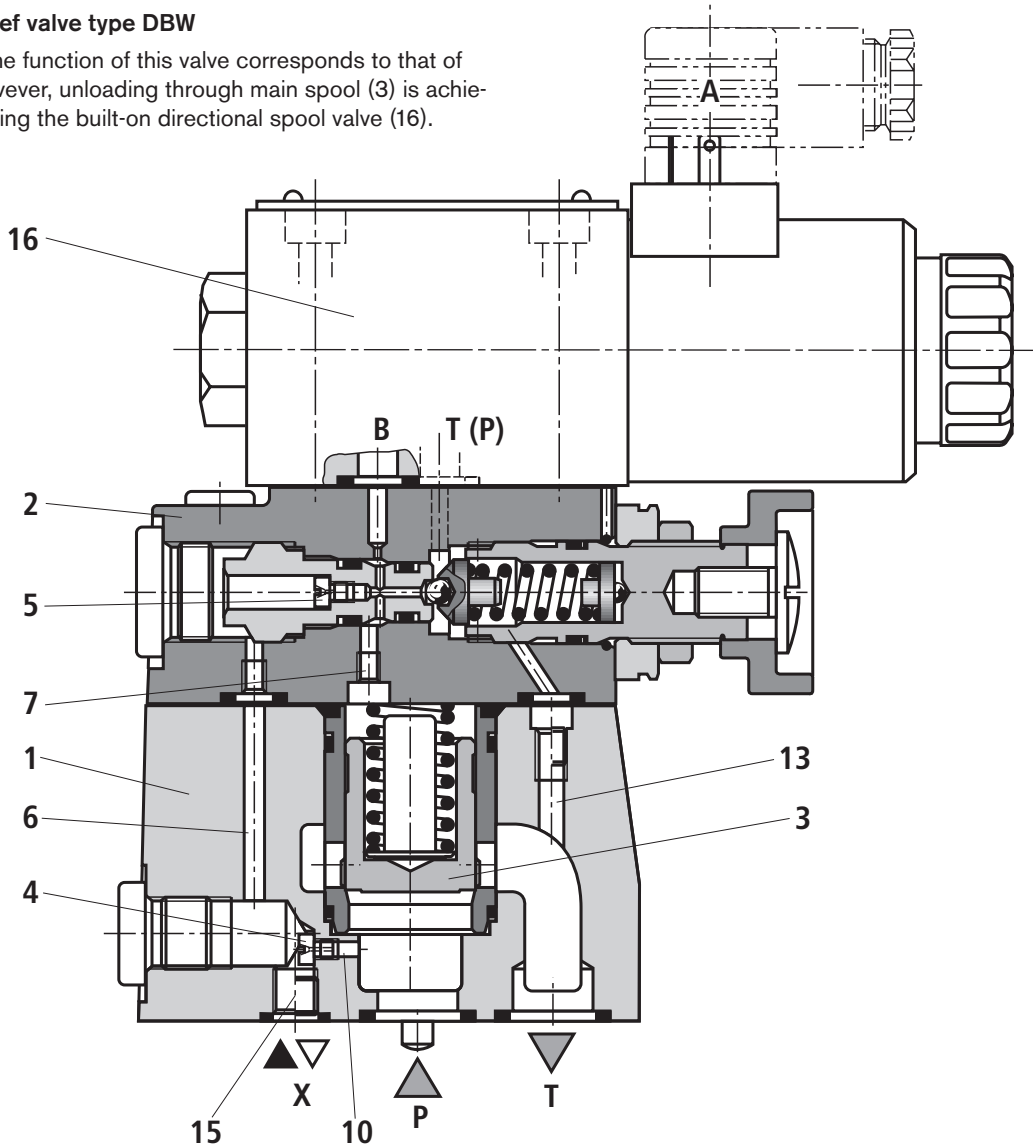

Pressure relief valve with switching shock damping (sandwich plate), type DBW.../..S6...R12

When a switching shock damping valve (17) is used, the connection from B2 to B2 opens with a delay, which prevents pressure peaks and acoustic unloading shocks in the return line. The valve is installed between pilot valve (2) and directional valve (16).

The degree of damping (unloading shock) is determined by the size of orifice (18). We recommend orifice $\varnothing 1.2$ mm (ordering code ..R12..).

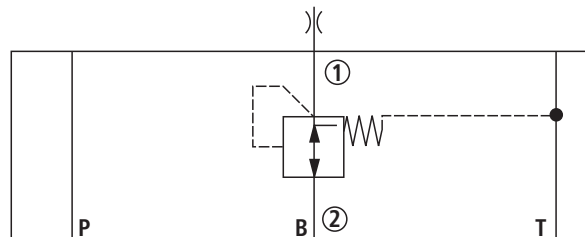
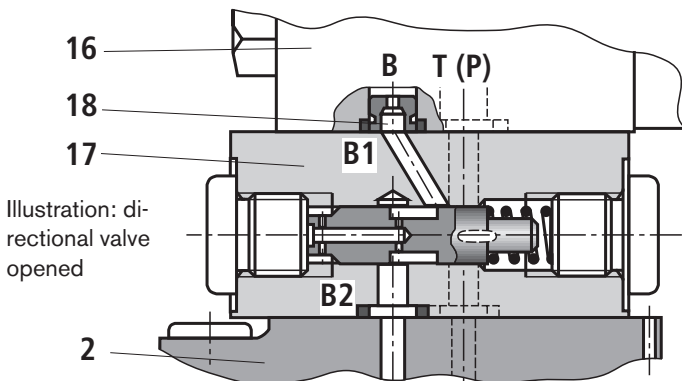

Technical data (for applications outside these parameters, please consult us!)

General								
Sizes				Size 10	Size 16 DB.. 15	Size 25 DB.. 20	Size 25 DB.. 25	Size 32
Weight	Subplate mounting	– DB...	kg	2.6	–	3.5	–	4.4
		– DBW...	kg	4.05	–	4.95	–	5.85
		– DBC...	kg	1.2				
		– DBWC...	kg	2.65				
		– DBC 10 or 30 ...	kg	1.5				
		– DBWC 10 or 30 ...	kg	2.95				
		Threaded connection	– DB...G	kg	5.3	5.2	5.1	5.0
– DBW...G	kg		6.75	6.65	6.55	6.45	6.25	
Installation orientation				Optional				
Ambient temperature range	– DB...	°C	–30 to +80 (NBR seals) –15 to +80 (FKM seals)					
	– DBW...	°C	–30 to +50 (NBR seals) –15 to +50 (FKM seals)					
Minimum strength of housing materials (for subplate-mounted and DBC../DBWC.. valves)				Select the housing materials so that sufficient safety is ensured under all operating conditions (e.g. with regard to compressive strength, thread stripping strength and tightening torques).				
Hydraulic								
Maximum operating pressure	– Ports P, X	bar	350					
	– Port T	bar	315					
Maximum backpressure	– Port Y (DB)	bar	315					
	– Ports Y, T (DBW)	bar	210 with DC solenoid 160 with AC solenoid					
Maximum set pressure		bar	50; 100; 200; 315; 350					
Minimum set pressure		Depends on flow (see characteristic curves on page 8)						
Maximum flow	– Subplate mounting	L/min	250	–	500	–	650	
	– Threaded connection	L/min	250	500	500	500	650	
Hydraulic fluid		Mineral oil (HL, HLP) to DIN 51524 ¹⁾ ; fast bio-degradable hydraulic fluids to VDMA 24568 (see also RE 90221); HETG (rape seed oil) ¹⁾ ; HEPG (polyglycols) ²⁾ ; HEES (synthetic esters) ²⁾ ; other hydraulic fluids on enquiry						
Hydraulic fluid temperature range		°C	–30 to +80 (NBR seals) –15 to +80 (FKM seals)					
Viscosity range		mm ² /s	10 to 800					
Max. permissible degree of contamination of the hydraulic fluid - cleanliness class to ISO 4406 (c)		Klasse 20/18/15 ³⁾						

For the technical data for directional poppet valve, see RE 22058, for the directional spool valve, RE 23178
For deviating technical data for type-tested safety valves, see page 16

¹⁾ Suitable for NBR and FKM seals

²⁾ Suitable only for FKM seals

³⁾ The cleanliness classes specified for components must be adhered to in hydraulic systems. Effective filtration prevents malfunction and, at the same time, prolongs the service life of components.

For the selection of filters, see data sheets RE 50070, RE 50076, RE 50081, RE 50086 and RE 50088.

Characteristic curves (measured with HLP46, $\vartheta_{oil} = 40\text{ °C} \pm 5\text{ °C}$)

Minimum set pressure and circulation pressure in dependence upon the flow ¹⁾

Standard version

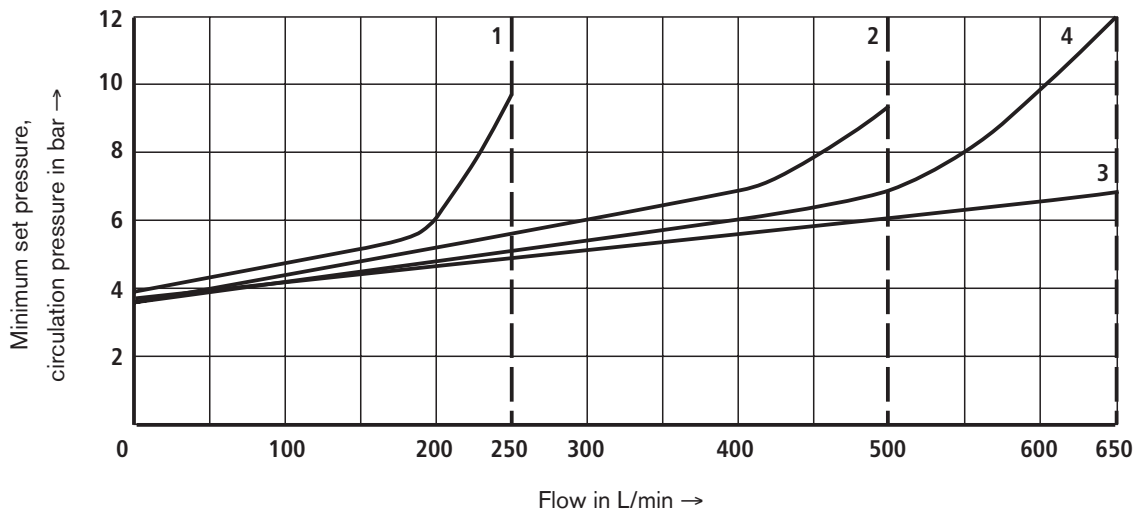

- 1 Size 10
- 2 Size 25
- 3 Size 32 (N)
- 4 DBC 30
DBWC 30

Minimum set pressure and circulation pressure in dependence upon the flow ¹⁾

Version "U"

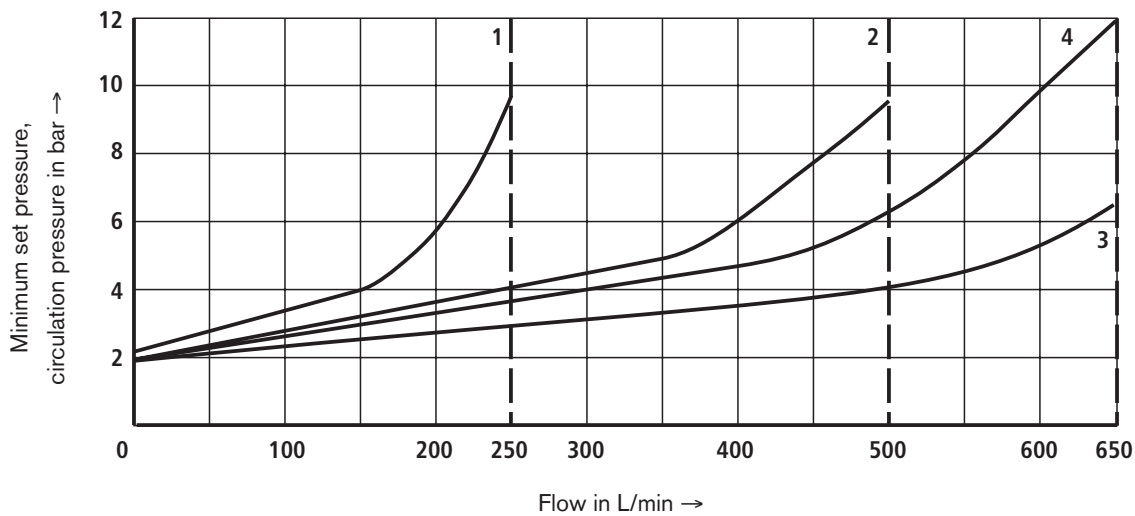

- 1 Size 10
- 2 Size 25
- 3 Size 32 (N)
- 4 DBC 30
DBWC 30

Note!

The characteristic curves were measured with **external, pressureless pilot oil drain**.

In the case of internal pilot oil drain, the inlet pressure increases by the outlet pressure present in port T.

¹⁾ The characteristic curves are valid for an outlet pressure of $p_T = 0$ over the entire flow range!

Characteristic curves (measured with HLP46, $\vartheta_{oil} = 40\text{ °C} \pm 5\text{ °C}$)

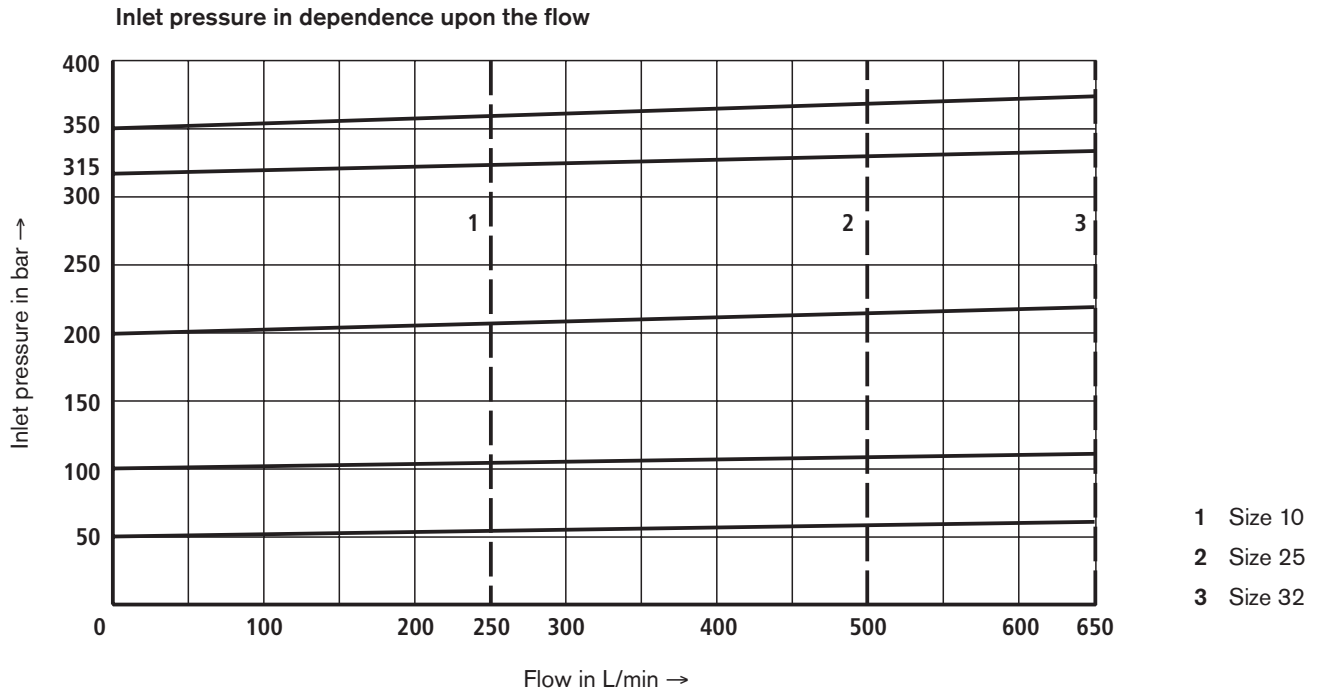

Note!

The characteristic curves were measured with **external, pressureless pilot oil drain**.
 In the case of internal pilot oil drain, the inlet pressure increases by the outlet pressure present in port T.

Characteristic curves (measured with HLP46, $\vartheta_{oil} = 40\text{ °C} \pm 5\text{ °C}$)

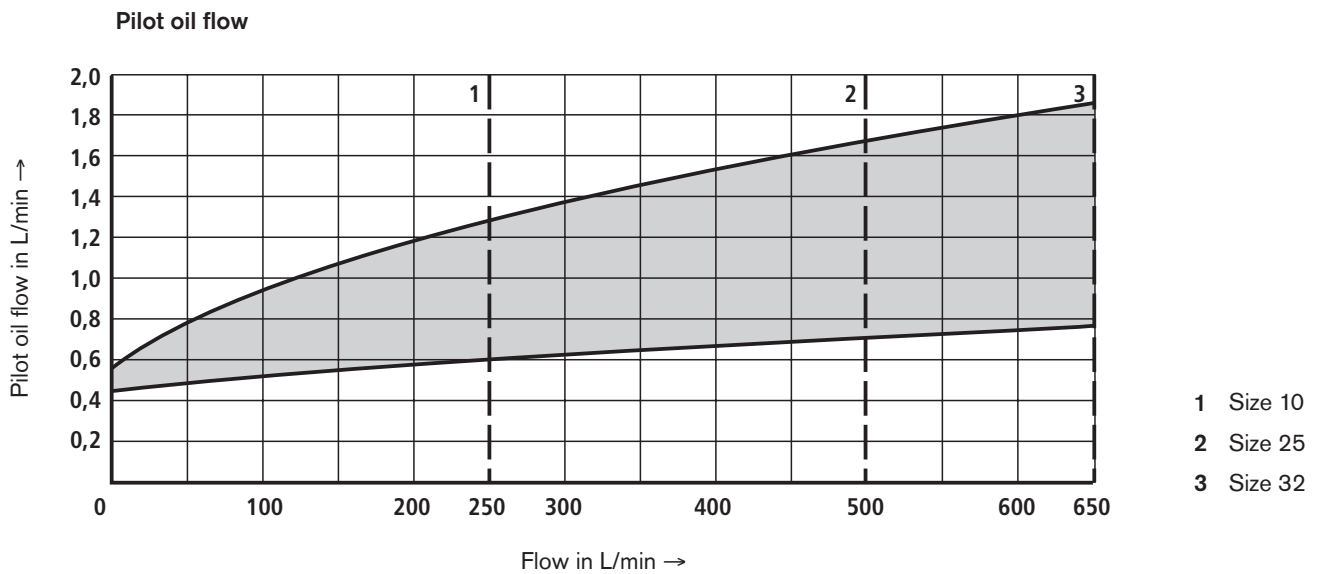

Unit dimensions: Threaded connection (nominal dimensions in mm)

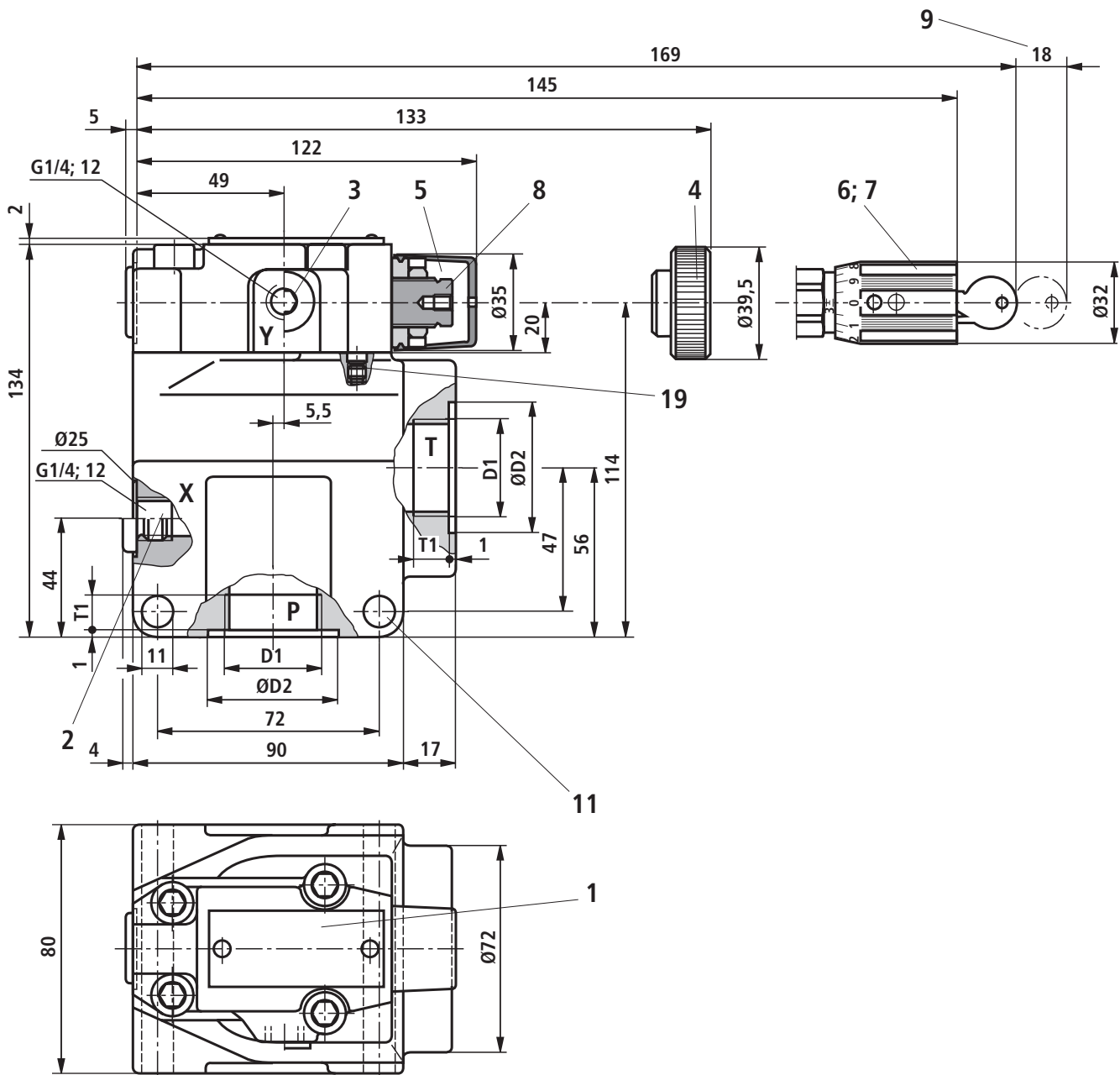

For the dimensions of the built-on directional valve, see pages 11 and 12

For explanations of items, see page 14

Type	D1	ØD2	T1
DB 10 G	G1/2	34	14
DB 15 G	G3/4	42	16
DB 20 G	G1	47	18
DB 25 G	G1 1/4	58	20
DB 30 G	G1 1/2	65	22

Unit dimensions: Subplate mounting with directional spool valve (nominal dimensions in mm)

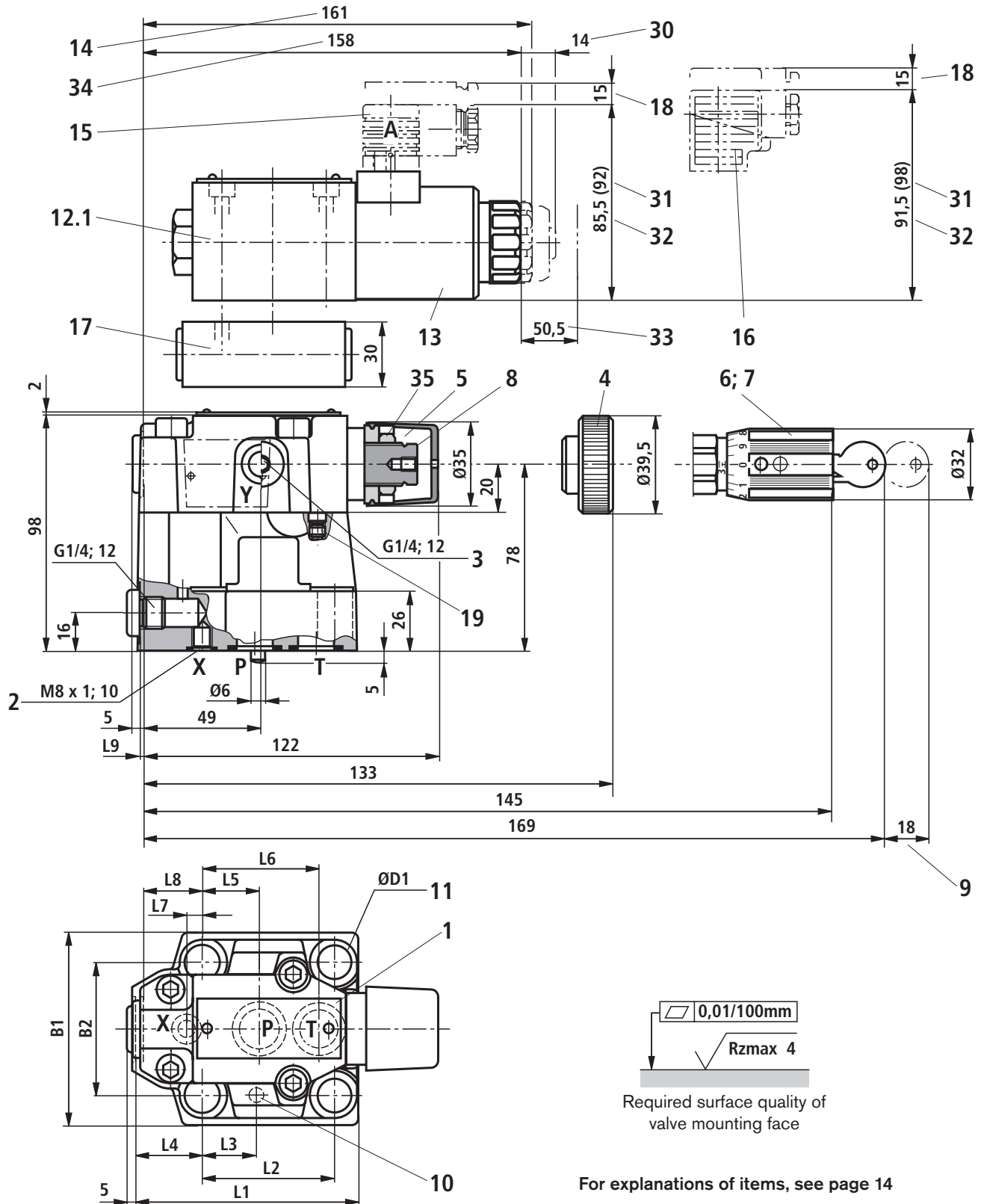

For explanations of items, see page 14

Type	L1	L2	L3	L4	L5	L6	L7	L8	L9	B1	B2	ØD1
DB. 10	91	53.8	22.1	27.5	22.1	47.5	0	25.5	2	78	53.8	14
DB. 20	116	66.7	33.4	33.3	11.1	55.6	23.8	22.8	10.5	100	70	18
DB. 30	147.5	88.9	44.5	41	12.7	76.2	31.8	20	21	115	82.6	20

Unit dimensions: Subplate mounting with directional poppet valve (nominal dimensions in mm)

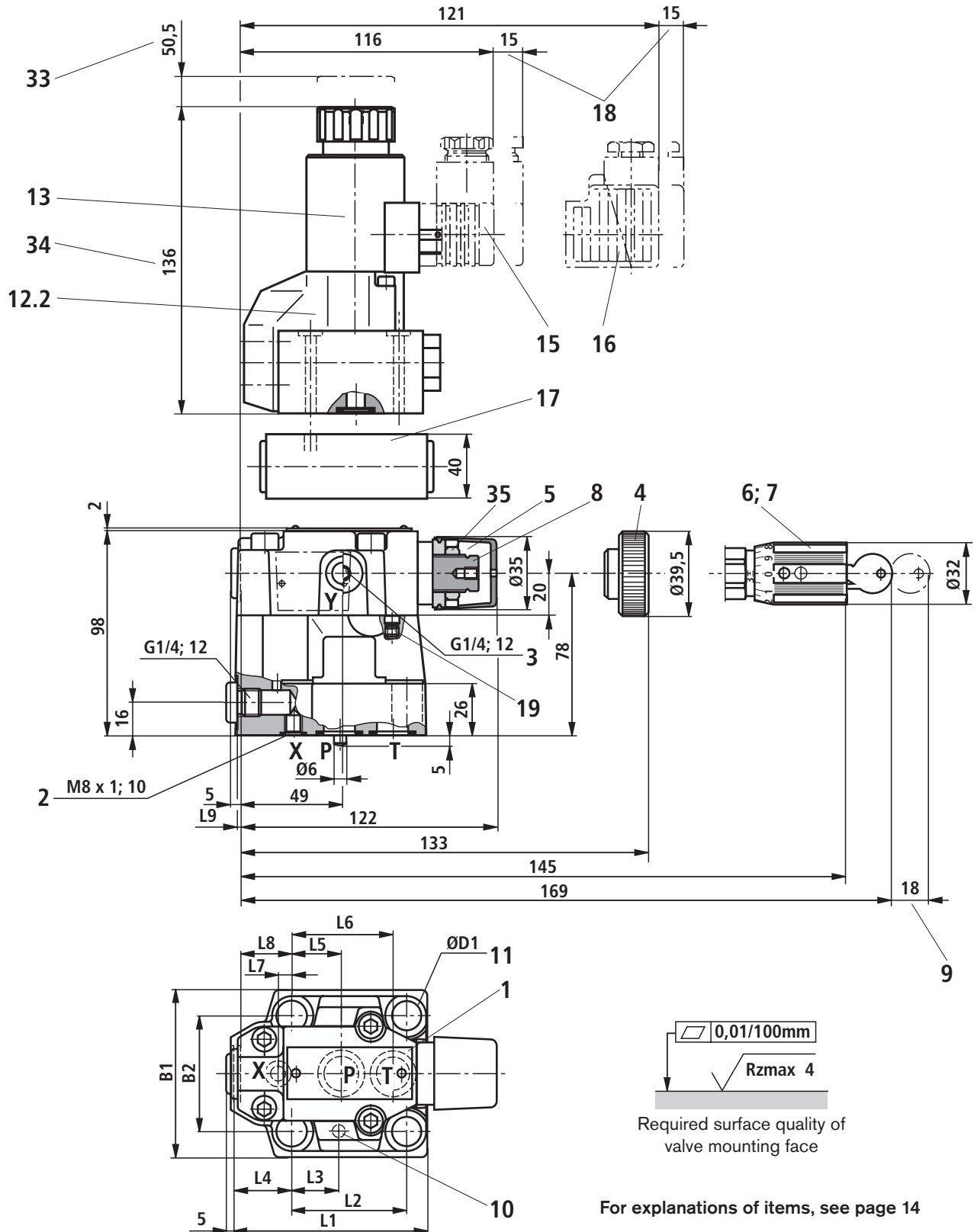

Type	L1	L2	L3	L4	L5	L6	L7	L8	L9	B1	B2	ØD1
DB. 10	91	53.8	22.1	27.5	22.1	47.5	0	25.5	2	78	53.8	14
DB. 20	116	66.7	33.4	33.3	11.1	55.6	23.8	22.8	10.5	100	70	18
DB. 30	147.5	88.9	44.5	41	12.7	76.2	31.8	20	21	115	82.6	20

Unit dimensions: Explanations of items

1	Nameplate	
2	Port X for external pilot oil supply	
3	Port Y for external pilot oil drain	
4	Adjustment element "1"	
5	Adjustment element "2"	
6	Adjustment element "3"	
7	Adjustment element "7"	
8	Hexagon A/F 10	
9	Space required to remove key	
10	Locating pin	
11	Valve fixing bore	
12.1	Directional spool valve size 6, see RE 23178	
12.2	Directional poppet valve size 6, see RE 22058	
13	Solenoid "a"	
14	Dimension for valve without manual override	
15	Cable socket without circuitry (separate order, see page 3)	
16	Cable socket with circuitry (separate order, see page 3)	
17	Switching shock damping valve, optional	
18	Space required to remove cable socket	
19	Not provided in the case of internal pilot oil drain	
20	Seal ring	
21	Main spool insert	
22	Bore Ø32 can intersect Ø45 at any point. However, care must be taken that connection bore X and the fixing bore are not damaged!	
23	The back-up ring and the seal ring must be inserted into this bore prior to the installation of the main spool.	
24	Orifice (separate order)	
25	Seal ring	
26	Seal ring	
27	Seal ring	
28	Back-up ring	
29	Back-up ring	
30	Dimension for valve with manual override "N"	
31	Dimension () for valve with AC solenoid	
32	Dimension for valve with DC solenoid	
33	Space required to remove solenoid coil	
34	Dimension for valve with concealed manual override "N9"	
35	Locknut A/F 17, tightening torque $M_T = 10^{+5}$ Nm	
		Subplates to data sheet RE 45064 (separate order) ¹⁾
		– Type DB/DBW 10 G 545/01 (G3/8) G 546/01 (G1/2)
		– Type DB/DBW 20 G 408/01 (G3/4) G 409/01 (G1)
		– Type DB/DBW 30 G 410/01 (G1 1/4) G 411/01 (G1 1/2)
		– Type DBT/DBWT G 51/01 (G1/4)
		¹⁾ ⚠ Caution!
		The subplates mentioned above are not approved for use with type-tested safety valves according to Pressure Equipment Directive 97/23/EC.
		Valve fixing screws (separate order)
		For strength reasons, only the following valve fixing screws may be used:
		– Type DB/DBW 10 4 off ISO 4762 - M12 x 50 - 10.9-flZn-240h-L at friction coefficient $\mu_{\text{total}} = 0.09$ to 0.14 , tightening torque $M_T = 75$ Nm $\pm 10\%$, material no. R913000283
		– Type DB/DBW 20 4 off ISO 4762 - M16 x 50 - 10.9-flZn-240h-L at friction coefficient $\mu_{\text{total}} = 0.09$ to 0.14 , tightening torque $M_T = 185$ Nm $\pm 10\%$, material no. R913000378
		– Type DB/DBW 30 4 off ISO 4762 - M18 x 50 - 10.9-flZn-240h-L at friction coefficient $\mu_{\text{total}} = 0.09$ to 0.14 , tightening torque $M_T = 248$ Nm $\pm 10\%$, material no. R900002245
		– Type DBC/DBWC, type DBC 10/DBWC 10 and type DBC 30/DBWC 30 4 off ISO 4762 - M8 x 40 - 10.9-flZn-240h-L at friction coefficient $\mu_{\text{total}} = 0.09$ to 0.14 , tightening torque $M_T = 31$ Nm $\pm 10\%$, material no. R913000205
		– Type DBT/DBWT 4 off ISO 4762 - M8 x 40 - 10.9-flZn-240h-L at friction coefficient $\mu_{\text{total}} = 0.09$ to 0.14 , tightening torque $M_T = 31$ Nm $\pm 10\%$, material no. R913000205
		The tightening torques given are guidelines when screws with the specified friction coefficients and a torque wrench (tolerance $\pm 10\%$) are used.

Ordering code: Type-tested safety valves of type DB(W)...E, component series 5X according to Pressure Equipment Directive 97/23/EC

	Designation	Component identification	Max. permissible flow $q_{V \max}$ in L/min with pilot oil drain		Set response pressure p in bar
			external "Y"	internal "-"	
10	DB 10 <input type="checkbox"/> <input type="checkbox"/> <input type="checkbox"/> -5X/ <input type="checkbox"/> <input type="checkbox"/> <input type="checkbox"/> E	TÜV.SV. <input type="checkbox"/> - 851.12.F.G.p	170	130	30 to 60
	DBW 10 <input type="checkbox"/> <input type="checkbox"/> <input type="checkbox"/> -5X/ <input type="checkbox"/> <input type="checkbox"/> <input type="checkbox"/> * <input type="checkbox"/> E		230	200	61 to 110
25	DB 20 <input type="checkbox"/> <input type="checkbox"/> <input type="checkbox"/> -5X/ <input type="checkbox"/> <input type="checkbox"/> <input type="checkbox"/> E	TÜV.SV. <input type="checkbox"/> - 852.22.F.G.p	230	200	111 to 210
	DBW 20 <input type="checkbox"/> <input type="checkbox"/> <input type="checkbox"/> -5X/ <input type="checkbox"/> <input type="checkbox"/> <input type="checkbox"/> * <input type="checkbox"/> E		230	200	211 to 350
32	DB 30 <input type="checkbox"/> <input type="checkbox"/> <input type="checkbox"/> N5X/ <input type="checkbox"/> <input type="checkbox"/> <input type="checkbox"/> E	TÜV.SV. <input type="checkbox"/> - 853.22.F.G.p	250	180	30 to 60
	DBW 30 <input type="checkbox"/> <input type="checkbox"/> <input type="checkbox"/> N5X/ <input type="checkbox"/> <input type="checkbox"/> <input type="checkbox"/> * <input type="checkbox"/> E		270	210	61 to 110
	DB 30 <input type="checkbox"/> <input type="checkbox"/> <input type="checkbox"/> N5X/ <input type="checkbox"/> <input type="checkbox"/> <input type="checkbox"/> E		420	320	111 to 210
	DBW 30 <input type="checkbox"/> <input type="checkbox"/> <input type="checkbox"/> N5X/ <input type="checkbox"/> <input type="checkbox"/> <input type="checkbox"/> * <input type="checkbox"/> E		450	400	211 to 350
	DB 30 <input type="checkbox"/> <input type="checkbox"/> <input type="checkbox"/> N5X/ <input type="checkbox"/> <input type="checkbox"/> <input type="checkbox"/> E		600	225	30 to 60
	DBW 30 <input type="checkbox"/> <input type="checkbox"/> <input type="checkbox"/> N5X/ <input type="checkbox"/> <input type="checkbox"/> <input type="checkbox"/> * <input type="checkbox"/> E		600	340	61 to 110
	DB 30 <input type="checkbox"/> <input type="checkbox"/> <input type="checkbox"/> N5X/ <input type="checkbox"/> <input type="checkbox"/> <input type="checkbox"/> E		650	540	111 to 210
	DBW 30 <input type="checkbox"/> <input type="checkbox"/> <input type="checkbox"/> N5X/ <input type="checkbox"/> <input type="checkbox"/> <input type="checkbox"/> * <input type="checkbox"/> E		700	580	211 to 350

- 1 Directional valve, normally closed = A
 Directional valve, normally open = B
- 2 For subplate mounting = No code
 For threaded connection = G
- 3 Adjustment element, hand wheel = 1
 (pressure setting sealed, unloading or setting of a lower response pressure possible)
 Adjustment element with sealed protective cap (adjustment/unloading impossible) = 2
- 4 Pressure in the designation to be entered by customer, e.g. pressure setting = 150
 ≥ 30 bar and in 5-bar increments possible
- 5 Pilot oil supply and drain internal = - 1; 2)
 Recommendation: Pilot oil supply internal, pilot oil drain external = Y 2)
- * Ordering code of electrical data = EG24N9K4
 (see page 3) e.g.
- 6 NBR seals = No code
 FKM seals = V
- Data entered in the factory

1) Hyphen "-" required **only** for version with built-on directional valve (DBW)

2) Pilot oil supply external "X" impossible!

Deviating technical data: Type-tested safety valves of type DB(W)...E, component series 5X according to Pressure Equipment Directive 97/23/EC ¹⁾

Hydraulic

Maximum backpressure	Port Y	bar	DB../..	DB../..Y	DBW../..	DBW../..Y
			–	0	–	0
	Port T	bar	²⁾	$p_T < 15$	²⁾	$p_T < 15$
Maximum flow	See table on page 15 and characteristic curves on pages 17 and 18					
Hydraulic fluid	Mineral oil (HL, HLP) to DIN 51524 and DIN 51524-1					
Hydraulic fluid temperature range	°C		–20 to +60 (NBR seals) –15 to +60 (FKM seals)			
Viscosity range	mm ² /s		12 to 230			

¹⁾ For applications outside these parameters, please consult us!

²⁾ See characteristic curves and explanations for max. permissible backpressures on pages 17 and 18

Safety notes: Type-tested safety valves of type DB(W)...E, component series 5X according to Pressure Equipment Directive 97/23/EC

- Before ordering a type-tested valve, make sure that at the desired **response pressure p** the max. permissible **flow $q_{V \max}$** of the safety valve is greater than the max. possible flow of the system / accumulator to be protected. Observe relevant regulations!
- **According to PED 97/23/EC** the increase in the system pressure caused by the flow must not be greater than 10% of the set response pressure (see component identification).
- Return lines (ports T and Y) of safety valves must provide a safe outlet. **No** fluid is allowed to collect in the return lines.
- When a seal is removed from the safety valve, the approval according to the PED becomes invalid!
- Generally observe the requirements laid down in Pressure Equipment Directive 97/23 EC and the AD2000 sheet A2!
- **⚠ Caution!**
The unloading function provided by the directional valve must not be used for safety-relevant functions! If an unloading function is required for safety-relevant tasks, an additional unloading valve must be installed.

Strictly observe the application notes!

The response pressure indicated in the component identification is factory-set at a flow of 2 L/min.

The permissible maximum flow $q_{V \max}$ indicated in the component identification (= numerical value in the place of letter “G” in the component identification, see page 15) must not be exceeded.

The following is valid:

- Pilot oil drain “**external**” (= Y in the ordering code) **without backpressure in return line Y**, permissible backpressure in the return line (port T) < 15 bar
- Pilot oil drain “**internal**” (= No code in the ordering code).
The max. permissible flow is only permitted **without backpressure in the return line** (port T).

With internal pilot oil drain, the system pressure increases by the backpressure in the drain line (port T) (AD2000 - sheet A2, observe section 6.3!).

In order to prevent this increase in the system pressure caused by the flow from exceeding 10 % of the set response pressure, the permissible flow must be reduced in dependence upon the backpressure in the return line (port T) (see diagrams on pages 17 and 18).

Safety notes: Type-tested safety valves of type DB(W)...E, component series 5X according to Pressure Equipment Directive 97/23/EC

Max. permissible flow q_{Vmax} in dependence on the backpressure p_T in the return line with internal pilot oil drain

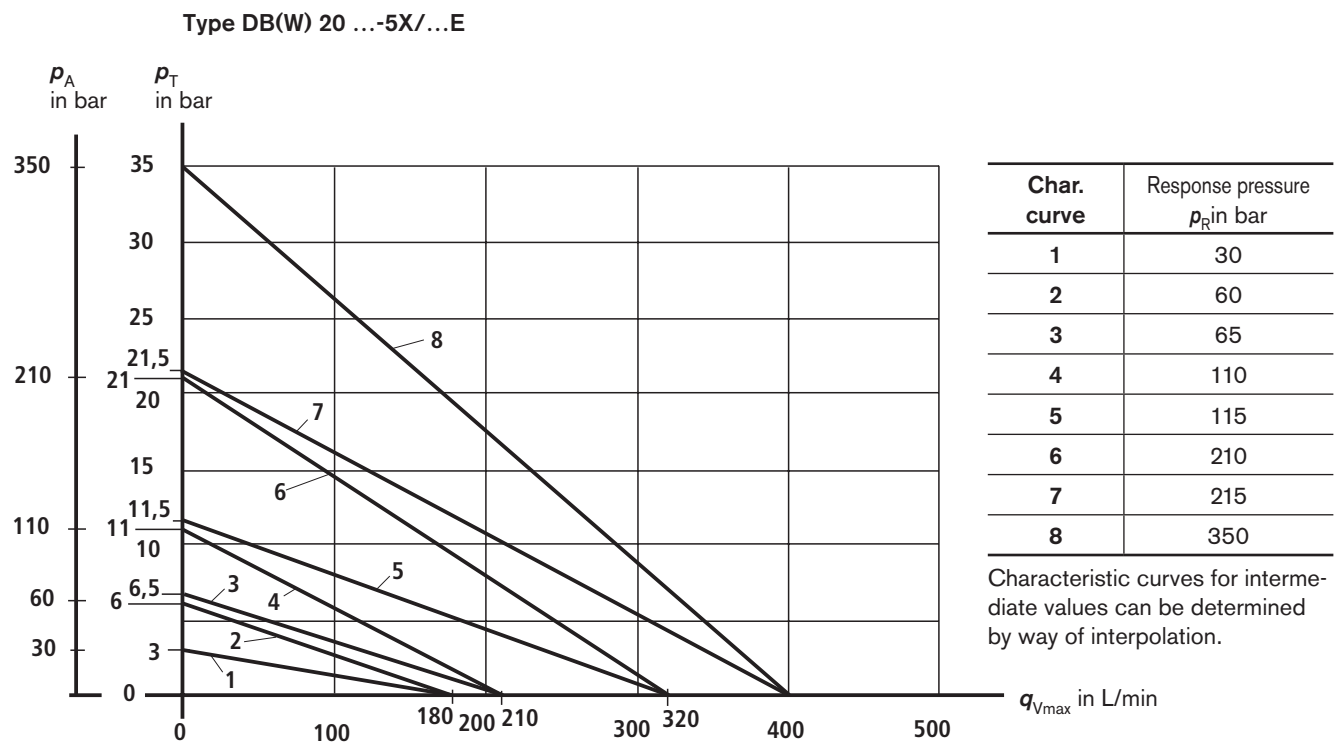
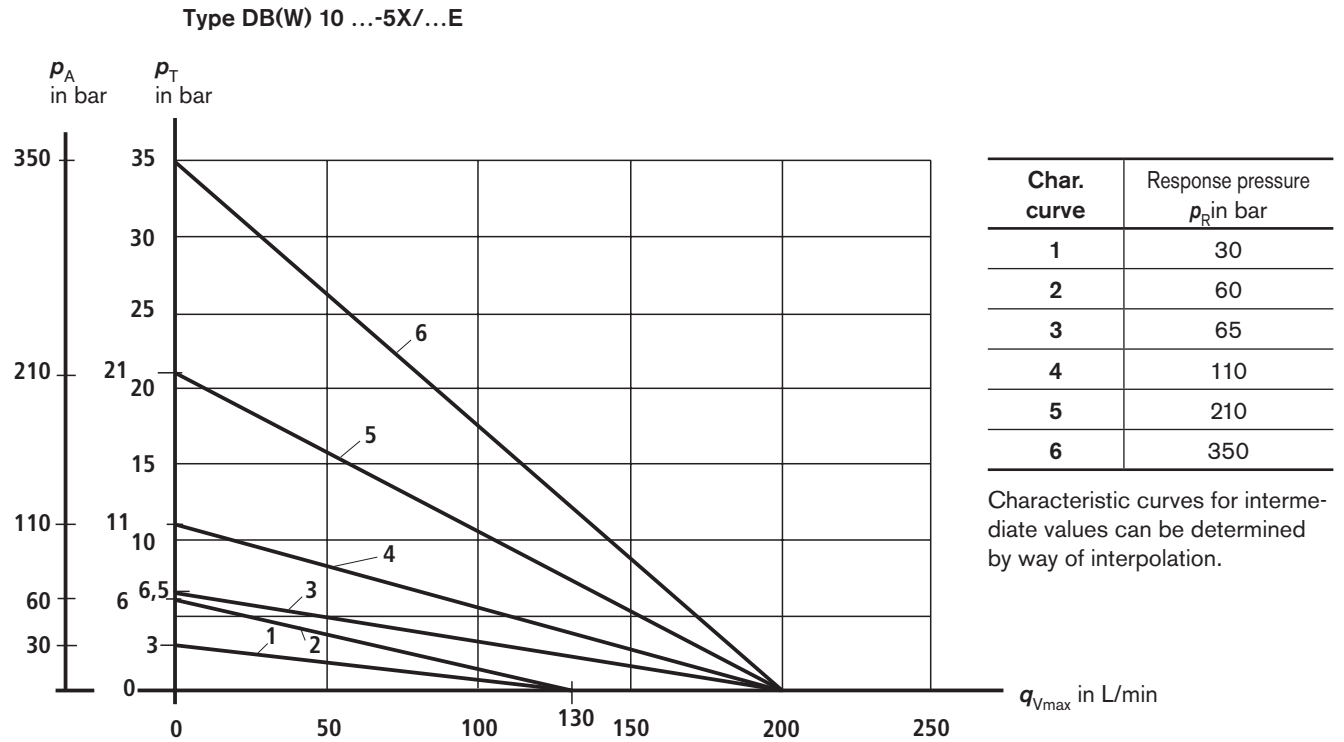

Safety notes: Type-tested safety valves of type DB(W)...E, component series 5X according to Pressure Equipment Directive 97/23/EC

Max. permissible flow q_{Vmax} in dependence on the backpressure p_T in the return line with internal pilot oil drain

Type DB(W) 30 ...-5X/...E

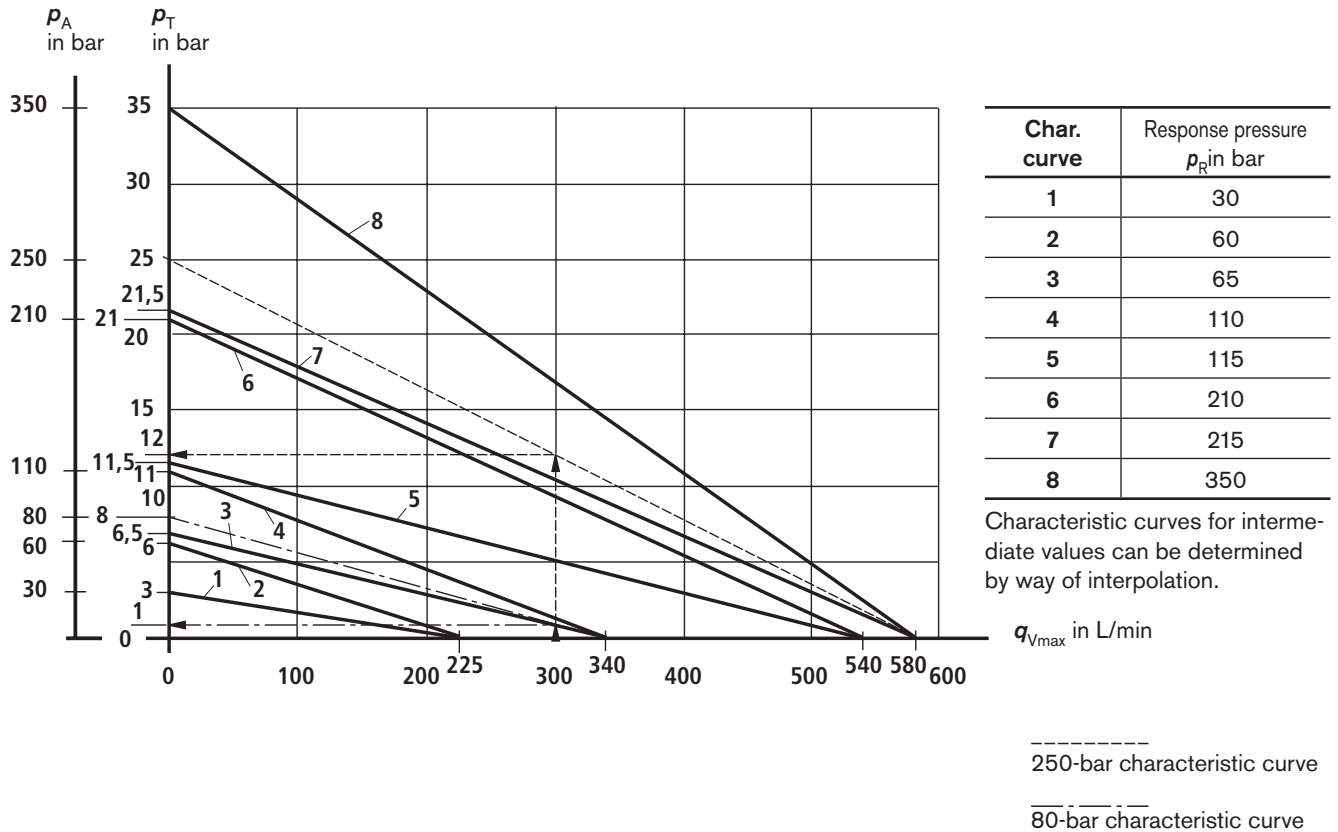

- p_A = Response pressure in bar
- p_T = Max. permissible backpressure in the return line (port T) (sum of all possible backpressures, see also AD2000 sheet - A2)
- p_{Tmax} = 10% x p_A (at $q_V = 0$ L/min) to PED 97/23/EC
- q_{Vmax} = Max. permissible flow in L/min

Explanation of diagrams (example DB(W) 30 ...E)

Example 1:
 Given: Flow of the system / accumulator to be safeguarded $q_{Vmax} = 300$ L/min
 Set response pressure of the safety valve $p_R = 250$ bar
 Required: $p_T = ?$
Solution: See arrows on the diagram:
 p_T (300 L/min; 250 bar) ~ 12 bar

Example 2:
 Given: Flow of the system / accumulator to be safeguarded $q_{Vmax} = 300$ L/min
 Set response pressure of the safety valve $p_R = 80$ bar
 Required: $p_T = ?$
Solution: See arrows on the diagram:
 p_T (300 L/min; 80 bar) ~ 1 bar

Notes

Notes

Bosch Rexroth AG
Hydraulics
Zum Eisengießer 1
97816 Lohr am Main, Germany
Phone +49 (0) 93 52 / 18-0
Fax +49 (0) 93 52 / 18-23 58
documentation@boschrexroth.de
www.boschrexroth.de

© This document, as well as the data, specifications and other information set forth in it, are the exclusive property of Bosch Rexroth AG. It may not be reproduced or given to third parties without its consent.

The data specified above only serve to describe the product. No statements concerning a certain condition or suitability for a certain application can be derived from our information. The information given does not release the user from the obligation of own judgment and verification. It must be remembered that our products are subject to a natural process of wear and aging.